

TECHNICAL DATA

COMBINATION ROLLER

BW 138 AC-5

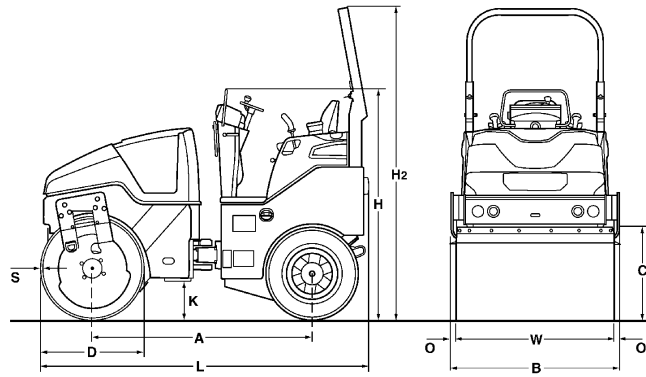



Dimensions in in

	A	B	C	D	H	H2	K	L	O	S	W
BW 138 AC-5	74.8	57.8	27.6	35.4	74.8	106.3	13.4	111.8	1.7	0.7	54.3

Shipping dimensions in cub.yd

BW 138 AC-5

without ROPS

10.358

with ROPS

14.721

Machine type	Compaction output (t/h) at different asphalt layer thicknesses		
	0.8-1.6 in	2.4-3.1 in	3.9-5.5 in
BW 138 AC-5	30-55	50-90	65-115

Technical Data

BOMAG BW 138 AC-5

Weights

Operating weight w. ROPS CECE	lb	9,039
Axle load, drum / wheels CECE	lb	4,519/4,519
Wheel load CECE	lb	1,129
Static linear load, front CECE	lb/in	83.2
Grossweight	lb	9,480

Dimensions

Working width	in	54.3
Track radius, inner	in	103.0

Driving Characteristics

Speed (1)	mph	3.1
Speed (2)	mph	6.2
Max. gradeability without/with vibr.	%	40/30

Drive

Engine manufacturer		Kubota
Type		V2403
Emission stage		4 final
Cooling		water
Number of cylinders		4
Performance ISO 14396	kW	33.6
Performance SAE J 1995	hp	45.1
Speed	min-1	2,400
Speed adjustment 1	min-1	2,300
Speed adjustment 2	min-1	2,530
Electric equipment	V	12

Drums and Tyres

Tyre size		10.5/80-16
Number of tyres		4

Brakes

Service brake		hydrost.
Parking brake		hydromec.

Steering

Steering system		oscil.artic.
Steering method		hydrost.
Steering / oscillating angle +/-	deg	32/10.0
Crab walk	in	0- 2

Exciter system

Vibrating drum		front
Drive system		hydrost.
Frequency	vpm	3,000/3,360
Amplitude	in	0.020
Centrifugal force	lb	10,116/12,814

Capacities

Fuel	gal	14.5
Water	gal	68.7
Emulsion	gal	13.2

Technical modifications reserved. Machines may be shown with options.

Standard Equipment

- Four smooth rear rubber wheels
- Hydrostatic travel and vibration drive
- Pressure sprinkler system with interval switch
- 2 scrapers per drum, spring loaded and tiltable
- Multi function travel lever
- Multi-function display incl. operating hour meter
- Water level
- electronic fuel gauge
- Emergency STOP
- Intelligent Vibration Control (IVC)
- Integrated stowage compartment
- Lashing eyes, galvanized
- Back-up alarm
- Single point lifting device
- Vandalism protection
- Lockable engine hood made of composite material
- Working lights front and rear
- 12V socket
- Seat contact switch
- Sliding seat incl. double travel lever

Optional Equipment

- *Foldable ROPS incl. seat belt
- Edge cutter
- Battery disconnect switch
- Indicator and hazard lights
- Rotary beacon
- Optional lighting on ROPS
- Sun roof, rigid
- Sun roof, foldable with ROPS
- Weather protection for sun roof
- Special painting
- Seat heating
- Backup warning buzzer with broadband technology
- Environmentally compliant hydraulic oil
- Tool kit
- Theft protection
- Thermal aprons
- BOMAG TELEMATIC
- ECONOMIZER
- Asphalt temperature display
- Gravel scatterer

* Standard delivery with CE conformity
(valid within European Union)

